



dekko

pool lighting system

Visit our website at www.oursplashlights.com

12V-LED Pool Lighting System
For Concrete-type Pools

ISIS – 22W All White

EOS – 30W All White

ARUNA – 30W RGB Color

OWNERS MANUAL AND INSTALLATION INSTRUCTIONS

IMPORTANT SAFETY INSTRUCTIONS ---- READ & FOLLOW ALL INSTRUCTIONS.

SAVE THESE INSTRUCTIONS.

Table of Contents:

- Section 1. Contents of package
- Section 2. Placement of fixture
- Section 3. Installing light fixture during new construction.
 - (a) CONCRETE Type Pool
 - (b) THIN WALLED (Liner, Fiber-glass, Concrete, Metal or Wooden form) Type Pool
- Section 4. Electrical Requirements.
- Section 5. Servicing the Light
- Section 6. After Market & Replacement Kits
- Section 7. For your Records
 - Warranty details
 - Registration and contact information

Part No: 60-000088 rev 12/10

Splash Lights, LLC • P.O. Box 244572 • Boynton beach • FL 33424-4572 • Tel: (561)740-8047 •



⚠ DANGER

Risk of Electric Shock or Electrocution.

ALWAYS DISCONNECT POWER TO THE POOL LIGHT AT THE CIRCUIT BREAKER BEFORE SERVICING THE LIGHT

This underwater light must be installed by a licensed or certified electrician in accordance with all National Electrical Codes and all applicable local codes and ordinances. Improper installation can create an electrical hazard which could result in death or serious injury to pool users, installer, or others due to electrical shock and may also cause damage to property. Read and follow the specific instructions below.



Important Notice

Attention Installer.

This manual contains important information about the installation, operation and safe use of this product. This information should be given to the owner/operator of this equipment.

⚠ WARNING

Before installing this product, read and follow all warning notices and instructions accompanying this light. Failure to follow safety warnings and instructions can result in severe injury, death, or property damage. Call (561) 740-8047 for additional copies of these instructions or download them from our website www.oursplashlights.com.

⚠ WARNING

This fixture is not intended for installation in a pool or spa floor. It must be installed in a vertically orientated wall. Failure to install the fixture properly could result in personal injury and/or property damage.

⚠ WARNING

Never operate this light fixture for more than sixty (60) seconds without its complete submergence in water. The fixture shall be installed in, or on, a wall of a pool with the top of the lens opening not less than 4" below the normal water level of the pool.

⚠ WARNING

Do NOT remove the Installation Shield until the Pool shell has been completed. The lens protective cover MUST be used in all installations.

⚠ IMPORTANT

This product is designed to be used with a UL listed class II transformer.

Only use genuine Splash Lights replacement parts – Failure to do so can invalidate the warranty.

Section 1 – Contents of package

Item No.	Item	Quantity	Replacement Kit Part No
1	Dekko light body Assembly	1	90-000020
2	Dekko deck box assembly	1	90-000025
3	Dekko outer guide conduit assembly	1	90-000035
4	Dekko inner umbilical Ass'y w/LED module	1	See section 6
5	Fascia cover-Plastic (bagged)	1	90-000040
6	'D' Assembly (bagged)	1	90-000045
7	Decals	1	Call for details
8	Warranty Registration form	1	Call for details
Optional Accessory Kits			See section 6
	Fascia cover-Stainless Steel		90-000060
	Concrete Installation Cover		90-000055
	Thin-walled Adapter Kit		90-000010
	Recessed Cov-a-lid – for concrete deck		90-000009C,G,T,W
	Recessed Cov-a-lid – for paver deck (ss)		90-000090

IMPORTANT

This standard light unit is designed to be used only in concrete-type pools.

Adapter kits for panel-type pools (Vinyl liner, reinforced plastic or fiber glass)

Are available separately by contacting your dekho light distributor/dealer.

Contents of package

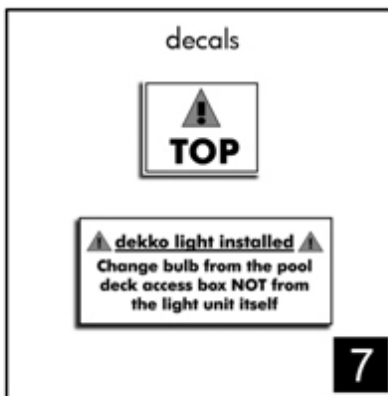
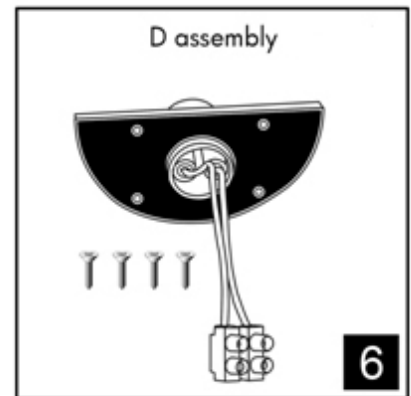
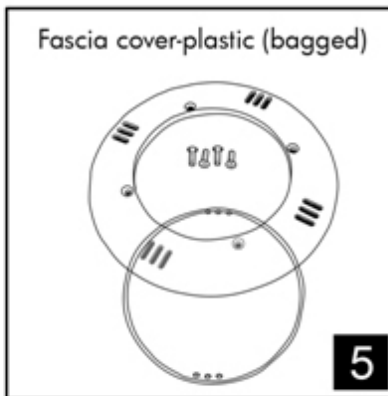
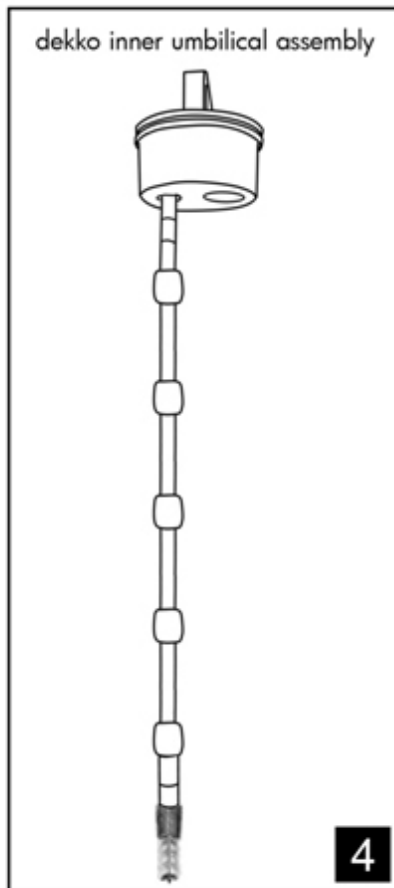
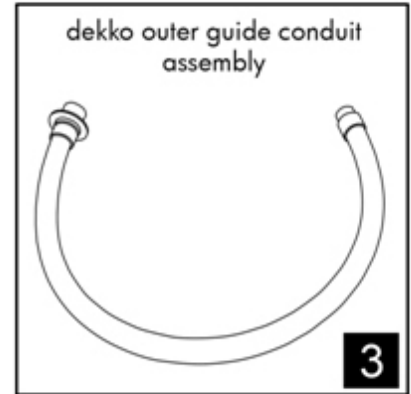

Check the contents of the box against the packing list and safeguard until needed.

Section 2 – Placement of fixture

In general, this light will illuminate an area of approximately 15'x30'. In order to minimize glare, it is recommended that the light should be installed facing away from the normal observation point.

Care must be taken not to install the light where swimmers are likely to make 'push-offs' and turns.

⚠ IMPORTANT

Except when the luminaire is installed in an area of the swimming pool that is not used for swimming and the lens is adequately guarded to keep any person from contacting it, the luminaire shall be installed in or on a wall of the pool, with the top of the lens opening not less than 4 inches below the normal water level of the pool

NEC also requires that the deck box shall be at least 48" from the inside edge of the pool (see illustration #1)

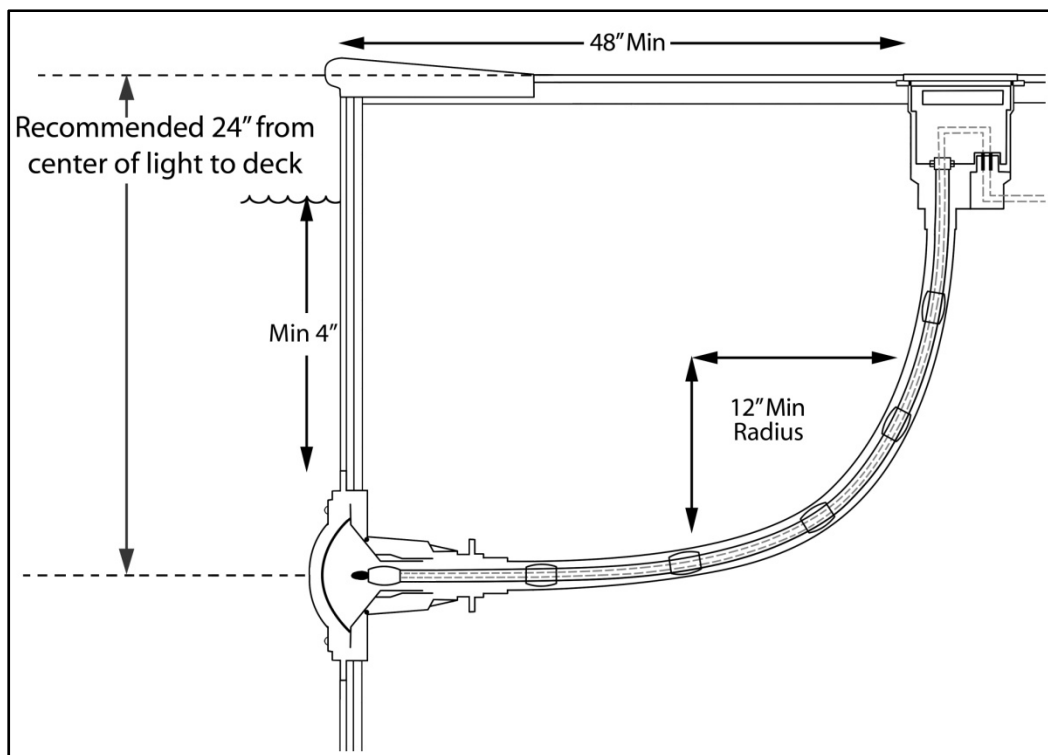

Note: If the distance required from the edge of the pool to the deck box is greater than 48" or if the light fixture is to be fitted lower than 24" below the deck level then please contact your dekkko light distributor regarding our custom-made service.

Section 3 – Installing light fixture during new construction

The dekho light must be installed in accordance with the National Electrical Code, NPFA 70. The unit as a whole is UL listed to Standard 676.

⚠ IMPORTANT

This is a Double-insulated, two-wire luminaire. It is designed for use **WITHOUT** a connection to an equipment-grounding conductor and with no provision for such connection.

⚠ IMPORTANT

Except when the luminaire is installed in an area of the swimming pool that is not used for swimming and the lens is adequately guarded to keep any person from contacting it, the luminaire shall be installed in or on a wall of the pool, with the top of the lens opening not less than 4" below the normal water level of the pool.

1. NEC also requires that the deck box shall be at least 48" from the inside wall of the pool (see illustration below)

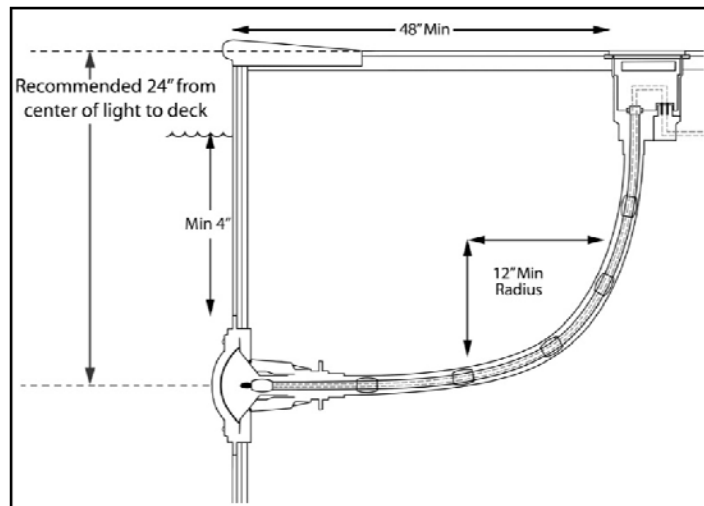

Illustration #1: showing light unit mounted 24" below pool deck and 48" from deck box to side of pool

Note: This dekho light is designed to be installed in a concrete/shotcrete/gunite (*) construction-type pool. An adapter kit for thin walled pools (Liner, Fiber-glass, Concrete, Metal or Wooden form type Pool) is available as an option (Part #: 90-000010).

Please contact your local distributor to order the adapter kit.

(*) Trademark of respective companies.

Section 3a – Installation in a CONCRETE Type Pool

REMINDERS

Read instructions **fully** before commencing installation

Always use a UL listed Class 2 transformer

Install in accordance with National Electrical Code and applicable any local codes.

INFORMATION

Panel-type construction technique

An adapter kit for installing the light in a panel-type constructed pool is available separately by contacting your dekho light distributor/dealer.

Adapter kit No: 90-000050

1. Firmly attach the outer guide conduit assembly (item 3) to the light body assembly (item 1) using the (1) fixing screw already in place on the body assembly (illustration #2).

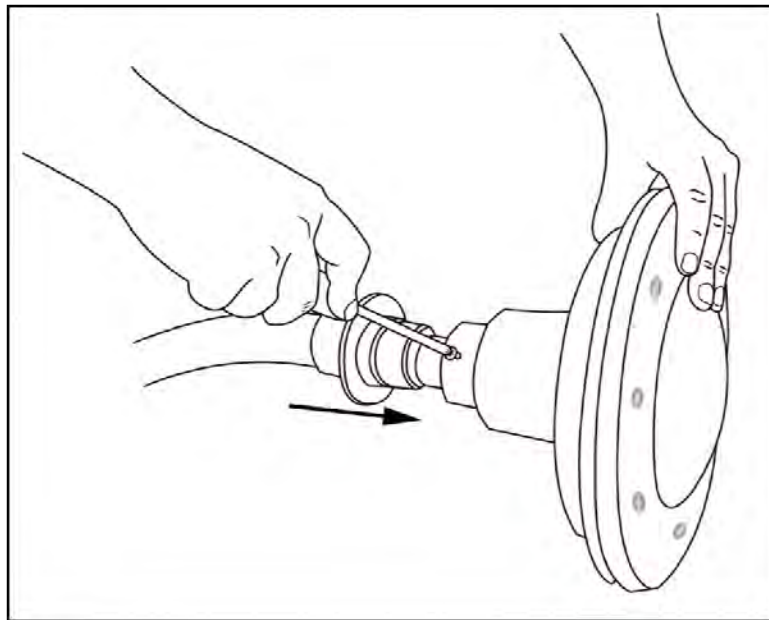

Illustration #2

- Using the enclosed cap, mask the other end of the outer guide conduit in order to prevent debris and back-fill from entering this conduit and in turn entering the light fixture during on-going site construction activities (illustration #3).

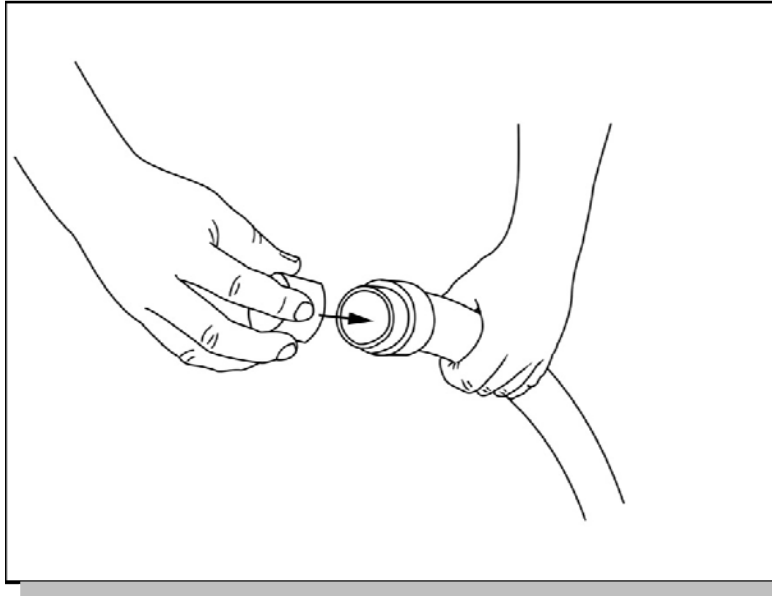

Illustration #3

- Ensure that the red disposable installation shield is firmly secured to the light fixture in order to prevent damage during shell construction e.g. concrete spraying process. Failure to have this shield in place could result in permanent damage to the fixture and will void any warranty.
- Determine the position of the light on the pool wall using the NEC requirements as stated above. (see illustration #1)

NOTE: Incorrect positioning of the light fixture on the pool wall may result in the deck box not complying with the 48" NEC requirement.

- Ensure that the outer guide conduit assembly follows a smooth, even radius from the light body assembly to the position where the deck box assembly will locate on the pool deck.

NOTE: When positioning the light body, ensure space is allocated for the finish surface - Make sure the light marking 'Top' is in the 12 o'clock position.

- Secure the light body assembly to the reinforcing framework or forms of the pool wall.
- Using standard, approved electrical practices connect the light assembly bonding terminal to the pool equipotential bonding grid. Per NEC Article 680.26 (C) and UL 676 clause 22.2.2 - Solid 8 AWG copper grounding wire MUST be used (illustration #4).

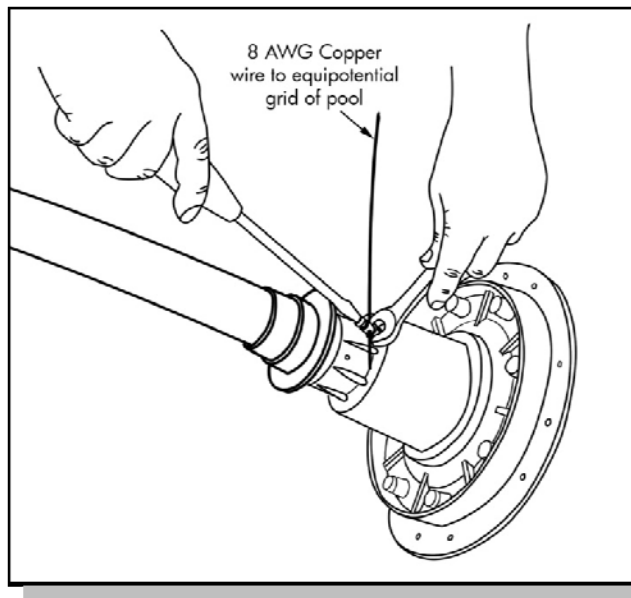

Illustration #4

8. Prior to pouring or spraying the concrete, make sure the light assembly is at the appropriate height, appropriate orientation and is leveled accordingly.
9. When spraying concrete take extra precaution around the light fixture. However, make sure the concrete is well-packed around the light body assembly and the connection with the outer guide conduit.
10. Upon completion of any spraying process, clean off any over-spray which may prevent the removal of the installation shield.
11. It is suggested that the red disposable installation shield is left in place until the final finishing around the light body is scheduled to be completed.
12. Upon completion of the pool finish, the fascia and lens protective cover can be fitted.

⚠ IMPORTANT

The fascia and lens protective cover **MUST** be fitted in order to complete the correct installation.

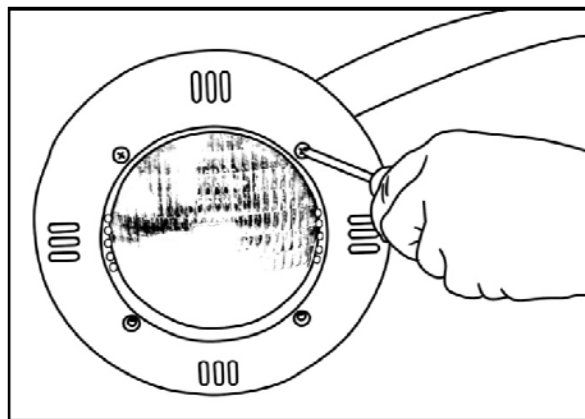

Illustration #5

Back-filling & Deck box fitting:

1. When back-filling, take care not to damage the outer guide assembly.
2. Back-filling around the outer guide should be done in such a way as to minimize any future ground settlement.
3. Remove the cap on the end of the outer guide conduit. Using an appropriate PVC/ABS adhesive, attach the outer guide conduit to the bottom of the deck box (item 2) (illustration #6).

Note: Ensure that the off-set of the Deck Box is orientated with the direction of the pool.

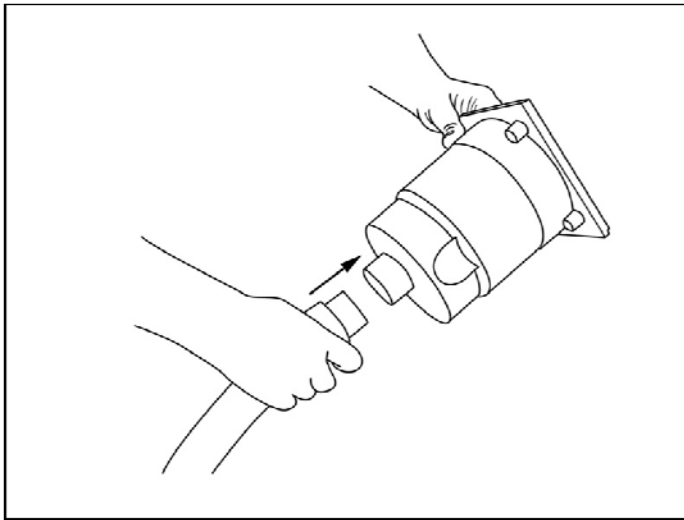

Illustration #6

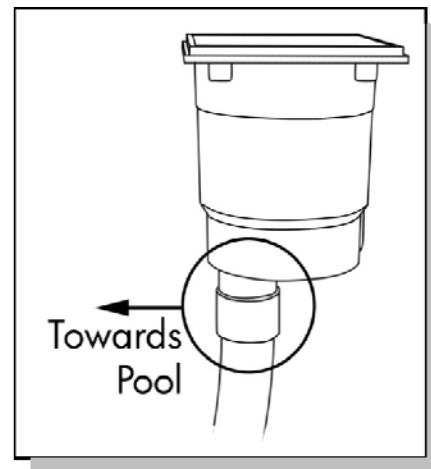

Illustration #7:

Note: Make sure that the connection between outer guide assembly and the deck box is closest to the pool.

Note: Both the deck box and the deck box lid are made from a paintable ASA polymer which is UV and mold stabilized. An acrylic paint in conjunction with a suitable primer can be used to match the deck box to any color you choose.

4. Ensure that the supplied deck box guide entry cover is over the guide hole in order to prevent any debris falling into the light body assembly (illustration #8).

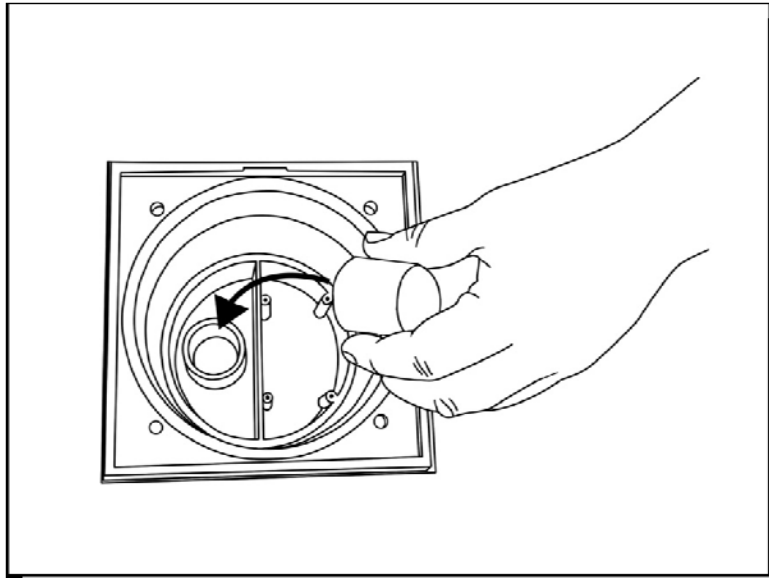

Illustration #8:

5. Install appropriate protection to the exterior of the deck box in order to prevent damage caused by other contractors working on the site.
6. Position the deck box such that it is a minimum of 48" from the edge of the pool and that the outer guide conduit follows a **smooth radius** of at least 12" to the light body assembly. (see illustration #1)

⚠ IMPORTANT

A radius that is too small may NOT allow for smooth extraction of the umbilical assembly and could cause it to 'lock-up' while changing the bulb.

Section 3b – Installation in a THIN-WALLED (Liner, Fiber-glass, Concrete, Metal or Wooden form) Type Pool

INFORMATION

This standard light unit is designed to be used only in concrete-type pools.

An adapter kit for panel-type pools (Liner, Fiber-glass, Concrete, Metal or Wooden panel) is available separately by contacting your dekho light distributor/dealer.

Adapter kit No: 90-000010

Section 4 – Electrical requirements:

IMPORTANT

This product is designed to be used with a UL listed class II transformer.

Only use genuine Splash Lights replacement parts – Failure to do so can invalidate the warranty.

1. When installing the class 2 transformer and supply cables refer to the transformer manufacturer's instructions.

Note: this LED light fixture is designed to operate on a 14VAC-16VAC 50/60 Hz supply.

IMPORTANT

Double-insulated, two-wire luminaire for use WITHOUT connection to an equipment-grounding conductor and with no provision for such connection

Making the electrical connections

1. Remove the deck box lid from the deck box assembly.
2. Retrieve the bagged 'D' assembly components (item 6).
3. Ensure that the deck box assembly is free of all debris and moisture.
4. Ensure that the 'D' gasket is adhered to the underside of the 'D' assembly.
5. Remove the deck box cable entry plug from the side of the deck-box. Install a suitable UL approved water-proof conduit connector.
6. Make the connection from the transformer output to the connector block on the 'D' assembly using suitable and approved electrical practices.
7. **Using a UL recognized NON-SETTING potting or encapsulate compound**, apply enough compound to submerge and protect the connections within the connector block (illustration #9).

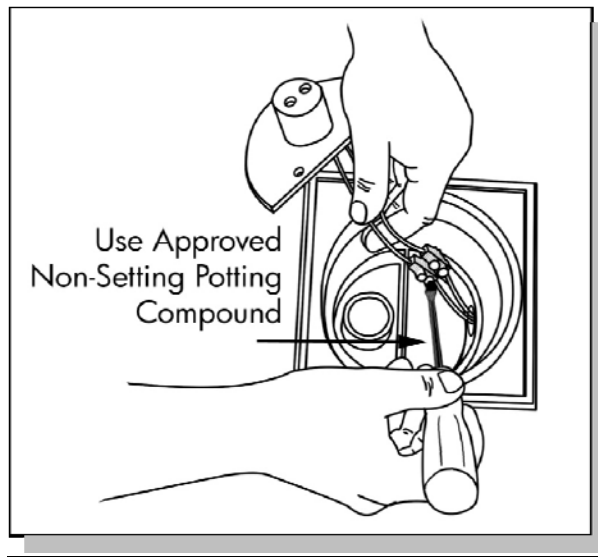

Illustration #9:

Note: Do not overfill with the potting compound. Leave enough space for the safe positioning of the tail wires.

8. This light fixture is Double-insulated. It is a two-wire fixture and designed for use WITHOUT a connection to an equipment-grounding conductor and has no provision for such connection.
9. Fold the tails from the 'D' assembly into the 'D' compartment taking care not to trap the wires.
10. Making sure the D shaped gasket is in place, firmly screw down the 'D' assembly into position using the (4) screws supplied (illustration #10).

Note: If the 'D' compartment is not mounted in a true vertical position, the umbilical assembly may not locate correctly. If this is the case, adjust the (4) mounting holes on the 'D' assembly in order to ensure the required vertical alignment.

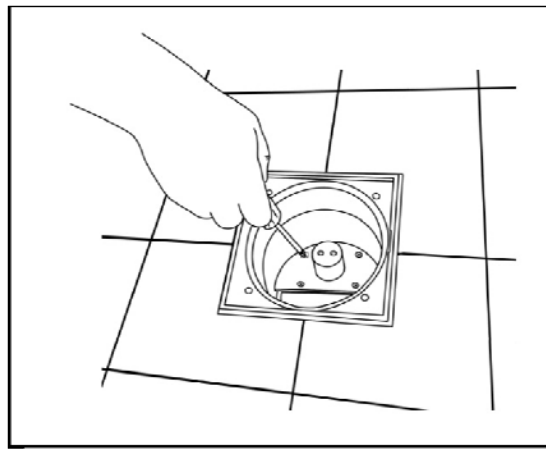

Illustration #10:

11. Carefully remove the protective cover of the LED module.

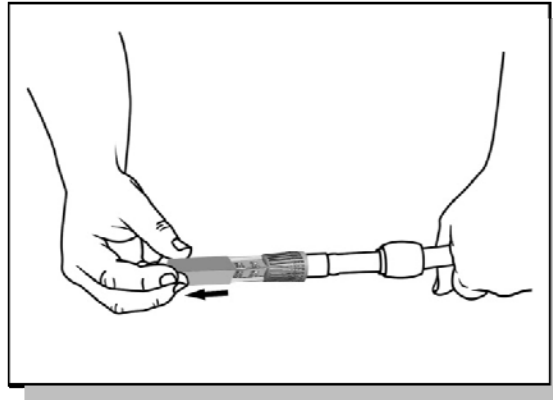

Illustration #11:

REMINDERS

In order to protect your warranty, do NOT insert LED assembly in to light housing if moisture is present. If moisture is present, contact Splash Lights directly for drying procedure.

12. Remove the deck box guide entry cover and insert the inner umbilical assembly. Make sure that while inserting the umbilical assembly it travels through the outer guide assembly in a smooth manner (illustration #12).

Note: Do NOT lubricate the LED or umbilical assembly as this can lead to contamination within the light body assembly.

13. Make sure the handle o-ring is lubricated and in place accordingly. Push the handle assembly into place to make a firm electrical connection within the deck box.

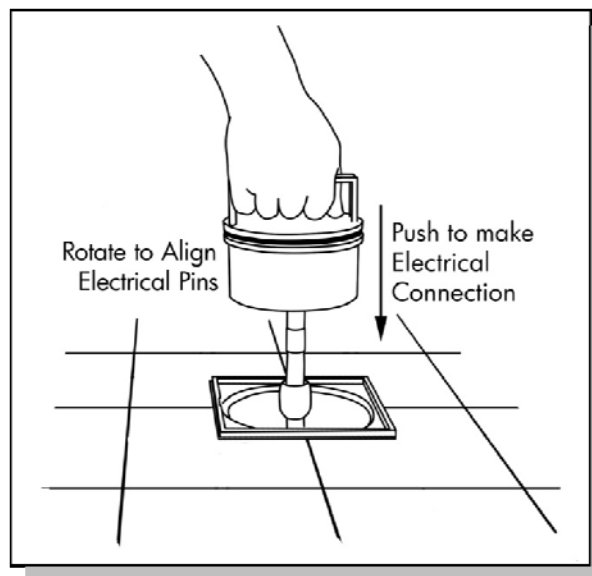

Illustration #12:

14. Make sure the O-ring is in place on the deck box lid.

Note: Maximum sealing is obtained when this O ring is lubricated with an appropriate O ring lubricant and that the lid is firmly located on the deck box.

15. Replace deck box lid and fix firmly using the (4) screws (illustration #13).

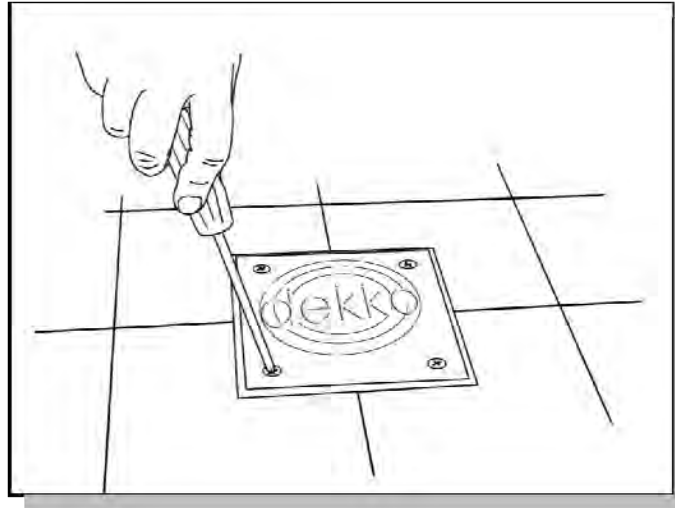

Illustration #13:

Section 5 – Servicing the Light

⚠ WARNING

Before removing the umbilical assembly, wait at least 30 minutes from the time the light was last illuminated as the unit runs very hot and can burn you and/or damage the interior of the light assembly.

- **IMPORTANT** – this light fixture is water cooled and should only be used when fully submerged in water.
- This light is designed to run with an on-load voltage at the deck box not exceeding 16 volts A.C. and this should have been verified by your electrician during installation. Voltages greater than 16V will reduce LED life significantly and may cause damage to the light fitting itself.
- This dekko light has been specifically designed for quick service & replacement. Unlike other underwater lights, it is not necessary to enter the water when servicing; it is done entirely on the pool deck via the deck box. This dekko light also significantly reduces cable damage as well as the chance of leaks developing; as no seals are broken in order to access the bulb. It also eliminates the possibility of contaminating the pool water during servicing as there is no risk of disturbing the organic sediment, which generally builds up between the light and its housing in other conventional underwater lights.

- Only use genuine Splash Lights parts – Failure to do so will invalidate the warranty.

Replacement kit #		Included
90-000101	Color + White	LED Module + umbilical assembly, O-Rings, Lubricant
90-000103	White-22W	LED Module + umbilical assembly, O-Rings, Lubricant
90-000105	White-30W	LED Module + umbilical assembly, O-Rings, Lubricant
90-000015	White-90W	90W Halogen + umbilical assembly, O-Rings, Lubricant
90-000018	White-65W	65W Xenon + umbilical assembly, O-Rings, Lubricant

- Do not carry out this operation if there is any likelihood of water entering the deck-box e.g. by splashing, rain or naturally draining water from other areas of the pool deck.
 1. Switch off the power at the main breaker box.
 2. Before removing the umbilical assembly, **WAIT AT LEAST 30 minutes** from the time the light was last illuminated as the unit runs very hot and can burn you and/or damage the interior of the light assembly.
 3. Remove the deck-box lid by unscrewing the 4 screws (illustration #14).
 4. Clean out any debris and/or moisture in or around the lid recess area.

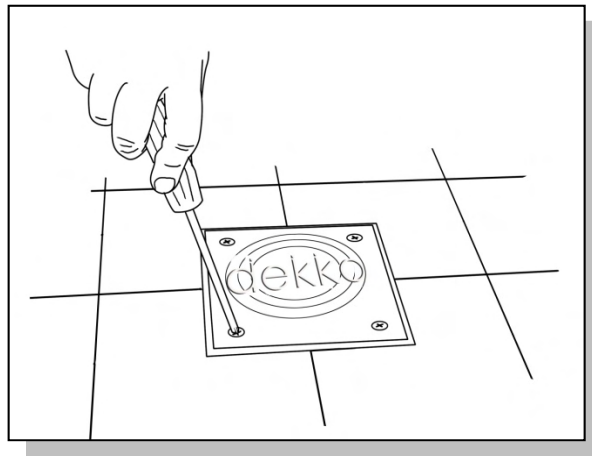

Illustration #14

5. Grasp the handle and gently remove the inner umbilical assembly (item 4) until the LED is fully exposed outside the deck box (illustration #15).

Note: The LED is very delicate and great care should be taken at all times.

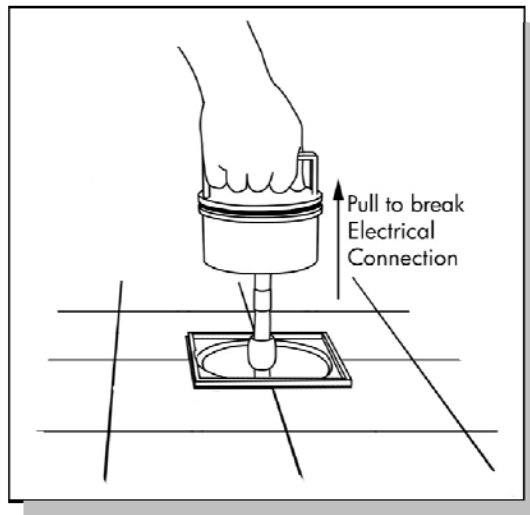

Illustration #15

6. Check the interior of the deck box for moisture. Clean & dry out if required.
7. Carry out the replacement or service work.
8. Replace the handle O-ring and lubricate it with O-Ring lubricant.
9. Carefully replace the inner umbilical assembly into the underwater light through the deck box, taking care when inserting the LED in to the guide hole.
10. Ensure that the handle assembly is firmly pushed in to place to ensure a good electrical connection (illustration #16).

⚠ IMPORTANT

In order to protect your warranty, do NOT insert LED assembly in to light housing if moisture is present. If moisture is present, contact Splash Lights directly for drving procedure.

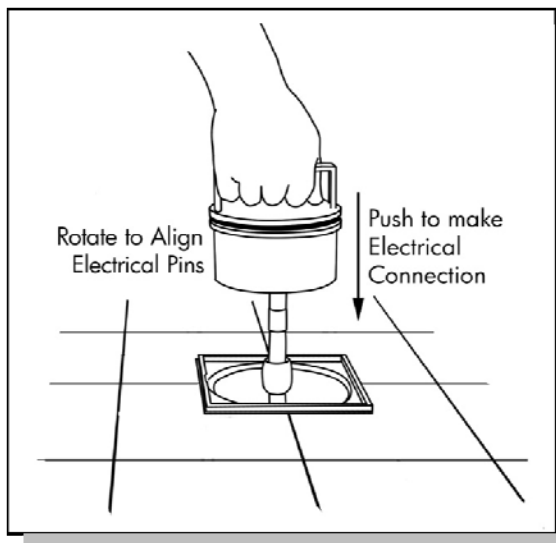

Illustration #16:

11. Install the new Deck Box lid O-Ring and lubricate accordingly. (Illustration #17).



Illustration #17:

12. Install the deck-box lid and **firmly** fasten down with the (4) screws (illustration #18).

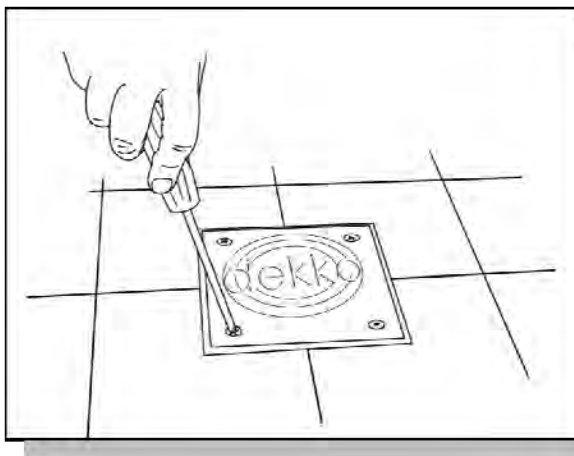

Illustration #18:

⚠ WARNING

Do not lubricate the inner light assembly as this may cause contamination throughout the light fixture.

⚠ WARNING

Failure to maintain water chemistry to industry standards could adversely affect the life of this light fixture.

⚠ WARNING

Should the deck box lid and/or the O ring become damaged, it should be replaced immediately to prevent ingress of water.

Section 6 – After Market & Replacement Kits:

<p>90-000010 <u>Thin Walled Adapter Kit</u></p> 	<p>90-000050 <u>Poured Concrete Sleeve Kit</u></p> 	<p>90-000055 <u>Sprayed Concrete Shield Kit</u></p> 
Installation Kits		

 <p><u>LED kits</u> 90-000110 - LED RGB + White 90-000210 - White 30W 90-000310 - White 22W</p>	LED Bulb Kits
--	----------------------

<p>90-000040 <u>White Fascia Kit</u></p> 	<p>90-000060 <u>Stainless Steel Fascia Kit</u></p> 	<p>90-000025 <u>Dekko Deck Box Assembly Kit</u></p> 	<p>90-000045 <u>'D' Assembly Kit</u></p> 
Fascia Kits			

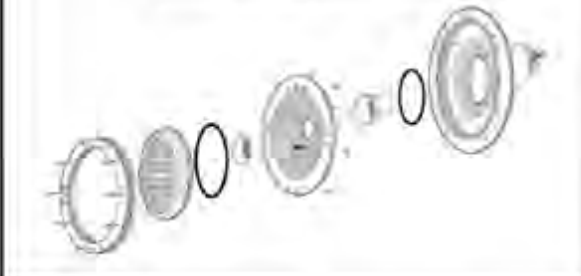
<p>90-000035 <u>US Pool Outer Guide Assembly Kit</u></p> 	<p>90-000020 <u>Dekko Pool Light Body Kit</u></p> 
Replacement Kits	

Section 7 – Warranty details, registration and contact information

3-YEAR LIMITED WARRANTY

Note: Product must be registered (see next page) in order to qualify for the 36 month limited warranty.

Splash Lights, LLC warrants its products, including incandescent or LED lamps but excluding service o-rings, to be free from defects in material and/or workmanship, under normal use, conditions and service, for a period of thirty six (36) months from the date of original purchase.

In the event of a defect in material or workmanship during the warranty period, Splash Lights will repair or replace (at its discretion) its products under the conditions of the warranty. Splash Lights will do so at its expense for the materials, but not the labor or shipping.

To obtain warranty service, contact the establishment that the product was originally purchased from.

EXCLUSIONS:

- 1) The dekho light is designed for in-ground swimming pools only and if installed in any other application, the warranty is void thus releasing Splash Lights, LLC from any and all claims related to its misuse.
- 2) Bulbs that require replacement, and qualify under the limited warranty, will be sent directly to the registered pool owner. Exclusions for bulb replacement include but are not limited to: Premature damage, loss or abuse, Incorrect installation causing physical damage, Incorrect installation causing over voltage. Any other of the non warranty situations specified in the product warranty.
- 3) The warranty does not cover and splash Lights, LLC shall be held harmless against any damage occurring during shipment, fair wear and tear, willful damage, failure resulting from alteration, accident, theft, abuse, negligent installation, voltage fluctuations, improper service or water-treatment, unauthorized repairs, failure to follow the seller's instructions (whether oral or in writing) or where adequate care has not been taken to prevent damage to the product.
- 4) Any claim by the Buyer which is based on any defect in the quality or condition of the Goods or their failure to correspond with specification shall (whether or not delivery is refused by the Buyer) be notified to the Seller within seven days from the date of delivery or (where the defect or failure was not apparent on reasonable inspection) within a reasonable time after discovery of the defect or failure. If the Buyer does not notify the Seller accordingly, the Buyer shall not be entitled to reject the Goods and the Seller shall have no liability for such defect or failure, and the Buyer
- 5) The Seller shall not be liable to the Buyer for any loss of profit or any indirect, special or consequential loss or damage, costs, expenses or other claims for consequential compensation whatsoever which arises out of or in connection with the supply of the Goods or their use or resale by the Buyer, except as expressly provided in these Conditions;
- 6) The Seller shall not be liable to the Buyer or be deemed to be in breach of these Conditions by reason of any delay in performing, or any failure to perform, any of the Seller's obligations in relation to the Goods, if the delay or failure was due to any cause beyond the Seller's reasonable control. Without prejudice to the generality of the foregoing, the following shall be regarded as causes beyond the Seller's reasonable control:-

Acts of God, explosion, flood, freezing, tempest, fire or accident;
War or threat of war, sabotage, insurrection, civil disturbance or requisition
Strikes, lock-outs or other industrial actions or trade disputes (whether involving employees of the Seller or of a third party)
- 7) Tampering with any internal part of the product will void any warranty.

This remedy is the sole and exclusive remedy for any and all claims relating to any breach of warranty by Splash Lights. Limitations, exclusions and other rights: 1) Except as provided herein, Splash Lights makes no other warranties, expressed or implied, including but not limited to the implied warranties of merchantability or fitness for a particular purpose, as all such warranties are expressly disclaimed. Some states do not allow the exclusion of an implied warranty, so the above exclusion may not apply to you. 2) Splash Lights is not responsible for defects or malfunctions in and/or damage to lighting systems where a sale is specifically made without warranty. In such sales the disclaimer of warranty and liability; set forth above, shall continue to apply. 3) The warranty covers normal consumer use and does not cover damage which occurs in shipment or damage or failure which results from alteration, accident, theft, misuse, abuse, abnormal use, negligent installation, improper maintenance or where adequate care has not been taken to prevent damage to the lighting system. 4) This warranty gives you specific legal rights, and you may also have other rights which vary from state to state. If you discover a defect or malfunction during the period to which the warranty applies, write or phone Splash Lights for information on receiving warranty service.

		Distance from Pool wall to side of deck box								
		4'	5'	6'	7'	8'	9'	10'	11'	12'
Distance from pool deck to CENTER of light fixture	2'	5' (standard)	6'	7'	8'	9'	10'	11'	12'	13'
	3'	6'	7'	8'	9'	10'	11'	12'	13'	14'
	4'	7'	8'	8'	9'	10'	11'	12'	13'	14'
	5'	8'	8'	9'	10'	11'	12'	13'	14'	15'
	6'	8'	9'	10'	11'	12'	12'	13'	14'	15'
	7'	9'	10'	11'	11'	12'	13'	14'	15'	16'

The above table is a guide to help identify the dekho model required for installations outside the standard 5 foot unit.

Special Order Service

Did you know that we offer a Special Order service which allows complete flexibility over where your lights can be located. If it's a resort-style pool with rocks, waterfalls, an informal shape and even with level changes, the dekho can be accommodated without compromising its unique qualities of easy access for servicing. Please contact your local dealer or visit our website at www.oursplashlights.com/special_order.html for more information.

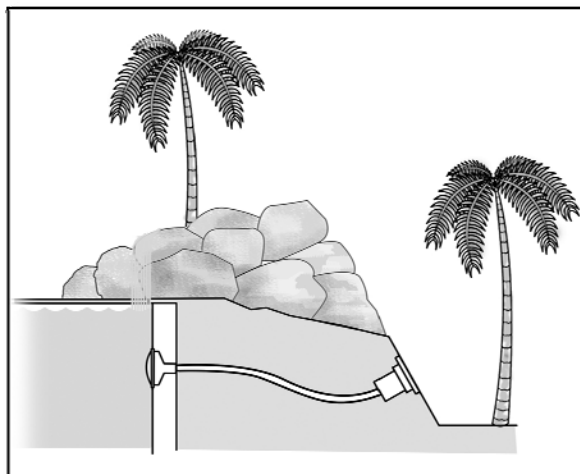

Example of a Special order configuration



Registration

Dealer Name: _____

(*) Customer Name: _____

(*) Customer Address: _____

(*) Customer City: _____

(*) Customer Zip: _____

Email: _____

(*) Model No: _____ Model No: _____ Model No: _____

(*) Serial No: _____ Serial No: _____ Serial No: _____

Product feedback:

(*) = Required fields

Registration options:

1. On-line at: <http://www.oursplashlights.com/registration.html>
2. Fax: 561-880-0318 Or scan and email to : registration@Oursplashlights.com
3. Mail this to: -

Splash Lights LLC - Registration Dept

PO Box 244572

Boynton Beach, FL 33424-4572